

Perissinotto s.p.a.



POMPE PEMO

PEMO PUMPS

TECHNICAL OVERVIEW

WHO IS PERISSINOTTO SpA?

- Started in 1947, we mainly manufacture specialty centrifugal pumps (PEMO Pumps) for abrasive and/or acid applications since 1953
- We sold and celebrated the 32,000th Pump last July 2012
- The present location (offices and workshop) is in Vimodrone (Mi), Italy, and covers an area of 12,000 m² (130,000 ft²)



LOCATIONS PERISSINOTTO SpA?

- Representatives & Agents:

Spain, Portugal, France, Holland, UK, Poland, Russia, Brazil, Egypt, South Africa, Singapore, Iran, India, South Korea, Australia, Canada, Usa, Mexico, Perù & Chile

- About 40% of our sales comes from direct sales worldwide.



- 30-40% of our sales are to Italian companies who sell our pumps worldwide.

MAIN APPLICATIONS OF PEMO PUMPS

- Stone Industry

PEMO is a World Leader
in pumps for granite gangsaws

One of our core businesses is the slurries in the granite gangsaws they have a specific weight of 1.7-2.2 kg/dm³, average viscosity of about 1200 cPo and a content of almost 700 g/liter of steel grit (size up to 1 mm).
Power up to 110 kW



- Ceramic Industry

PEMO is a World Leader for pumps that transfer ceramic slip

Another one of our core businesses. In some plants there are hundreds of PEMO pumps of all types and models. Max Flows of 1200 m³/h (5300 GPM)



• Chemical Industry

There are a growing number of PEMO pumps being used within the chemical industry. And the ones that have been installed are amongst the most important and expensive!

Usually these pumps deal with both acids and abrasive particles. Many have parts made of special alloys.



- Filter-Press Feeding

This is an application where in most cases PEMO pumps have little or no competition, thanks to our DC (double stage) pumps.



- Steel Mills



PEMO pumps are widely used to transfer hot water up to 80 °C (176 °F) with a presence of oil and metal flakes. They are also used in water treatment plants.



PEMO PUMPS TECHNOLOGY FOR THE TRANSFER OF SLURRIES

- **Quarries and Inert Materials Excavation**

PEMO pumps are used in feeding separating cyclons and to transfer slurries in ponds, yellowcake applications and water treatment plants just to name a few.



R&D ACTIVITY IN PERISSINOTTO



- 4-5% of all sales income is used for R&D
- Continuous interaction with our customers and suppliers

PEMO PUMPS TECHNOLOGY FOR THE TRANSFER OF SLURRIES

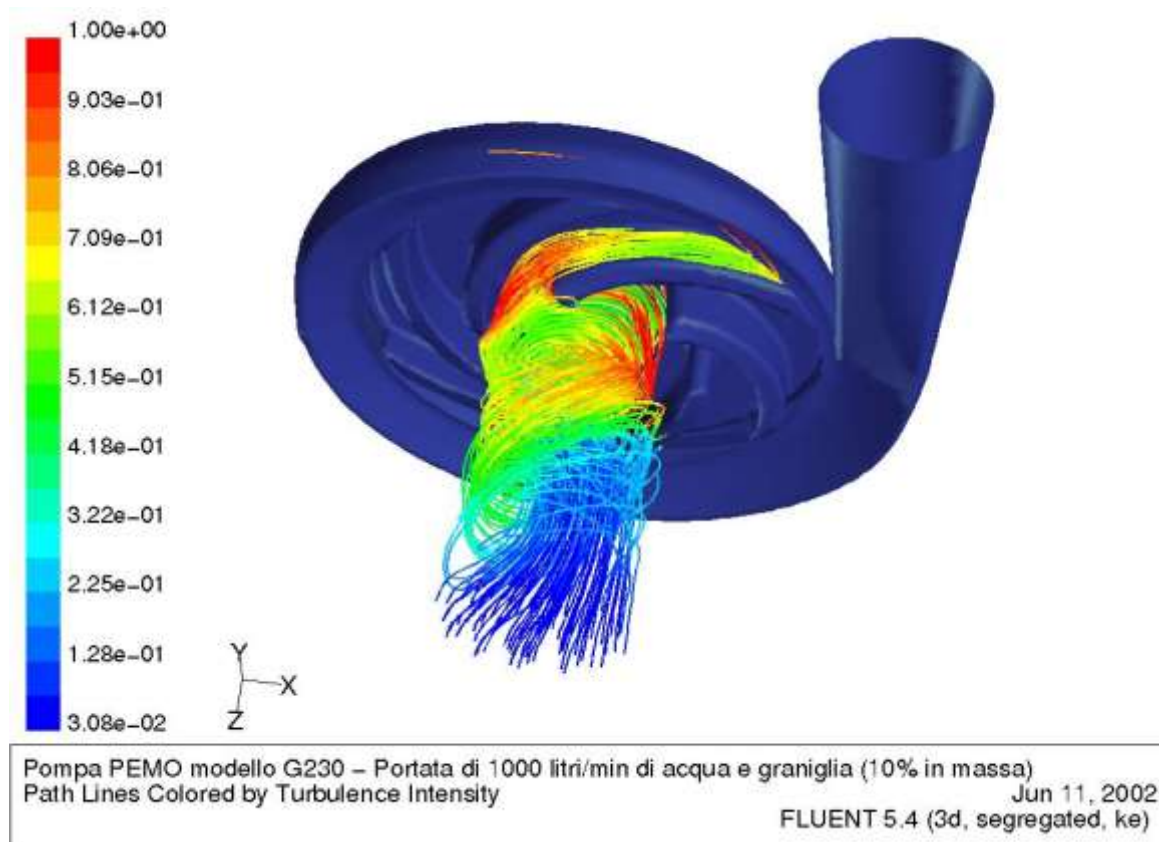

- Dynamic Fluid studies
- Continuing Research on new materials

PEMO PUMPS TECHNOLOGY FOR THE TRANSFER OF SLURRIES

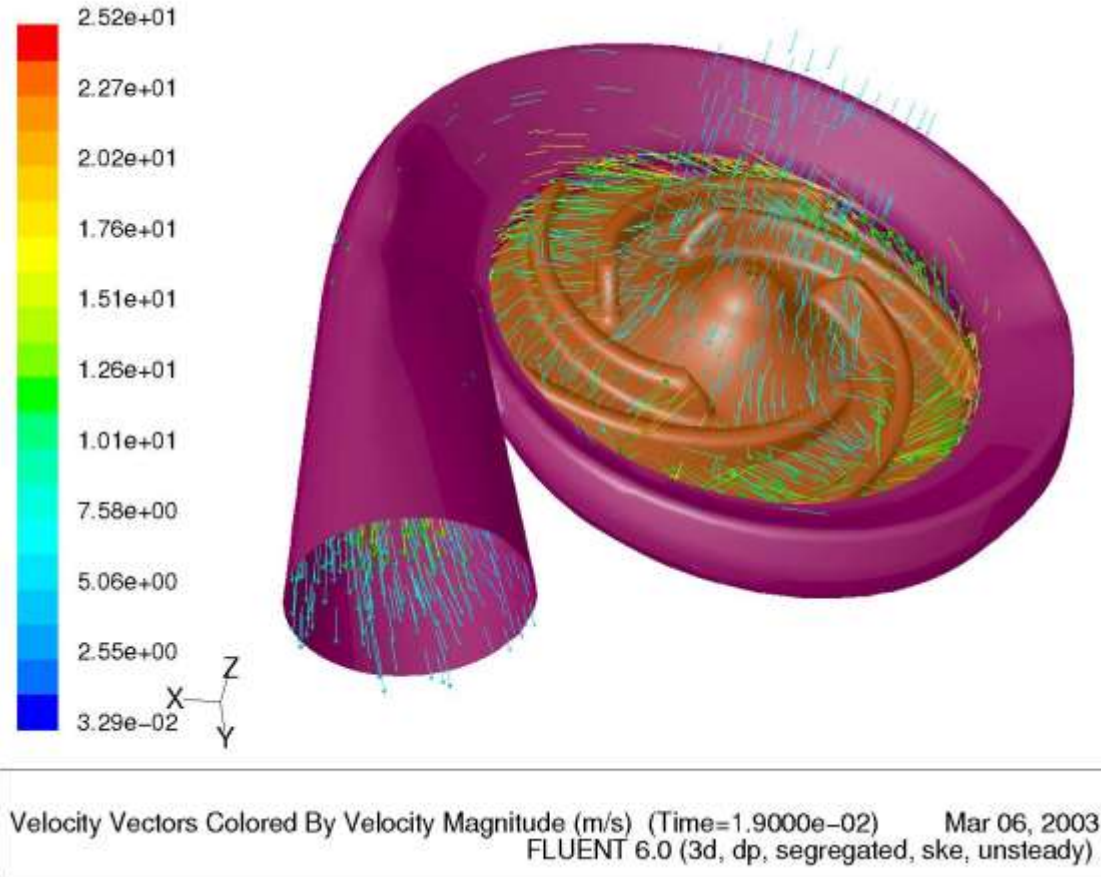

- Revision and updating existing Models
- Advancement of a new model almost every year

• COMMON FEATURES TO PEMO PUMPS

Impellers:

- Open type
- Made of:
 - a) A metal core, coated with a thick layer of different rubber.
 - b) Metal Type:
Hardalloy PEMO, AISI, Hastelloy C and others



- *Rubberized Casings*
- Built in 2 half shells
- Made mostly of cast iron for some models it is possible to mold them in stainless, Hastelloy or other metals.
- The interior is protected with vulcanized or separable linings made of rubber, having different composition depending on the liquid



Advantages:

rubber separable linings

- Less expensive to buy, to transport and easier to change.

Disadvantages

rubber separable linings

- Depending on the model and the amount of abrasive in the fluid or the slurry to be pumped it sometimes does not stand high rotational speeds.



Coating:

Most of PEMO Pumps have parts coated with natural rubber or a syntetic (neoprene, nitrile, butile, EPDM, etc.)

Advantages of rubber:

- Rubber protects from abrasion
- Rubber also gives an excellent protection from chemical attacks: depending on the properties of the fluid to be pumped, it is possible to choose among hundreds of rubber compositions



Disadvantages of Rubber:

- Rubber does not resist high temperatures (>120 °C, or 248 °F)
- Because of high rotational speeds, rubber could be teared apart on the tips of the impellers
- Rubber doesn't stand coal abrasion
- Rubber makes it impossible to dynamically balance the impellers

Because of the above, PEMO manufactures most of our pumps with impellers, and some models with casings as well, that are made of: HARDALLOY PEMO (HRC 70-80, or 700-800 HB)

PEMO PUMPS, THE MODELS

- 18 different basic models are currently in production:
33, 302, 403, 423, 503, 523, 533, 603, 804, K125, 1004, 1023, 1204, P200, 1706/99, G230, I-270, C300.
- 6 different all-Hardalloy models are currently in production:
S/ATM(FP), 603-H, K125-H, 1004-H, P200-H, 1706/99-H
- Capacities (flows) range between a few liters
to over 25000 liters per minute (1500 m³/h, or 6600 GPM)
- Output pressure for single stage pumps varies from
a few meters to 80-90 m/H₂O (almost 300 feet)

PEMO PUMPS, NEW IN 2012 (1)

- One all Hardalloy pump, the model 1706-H (October 2012) for flows up to about 360 m³/h (1600 GPM)

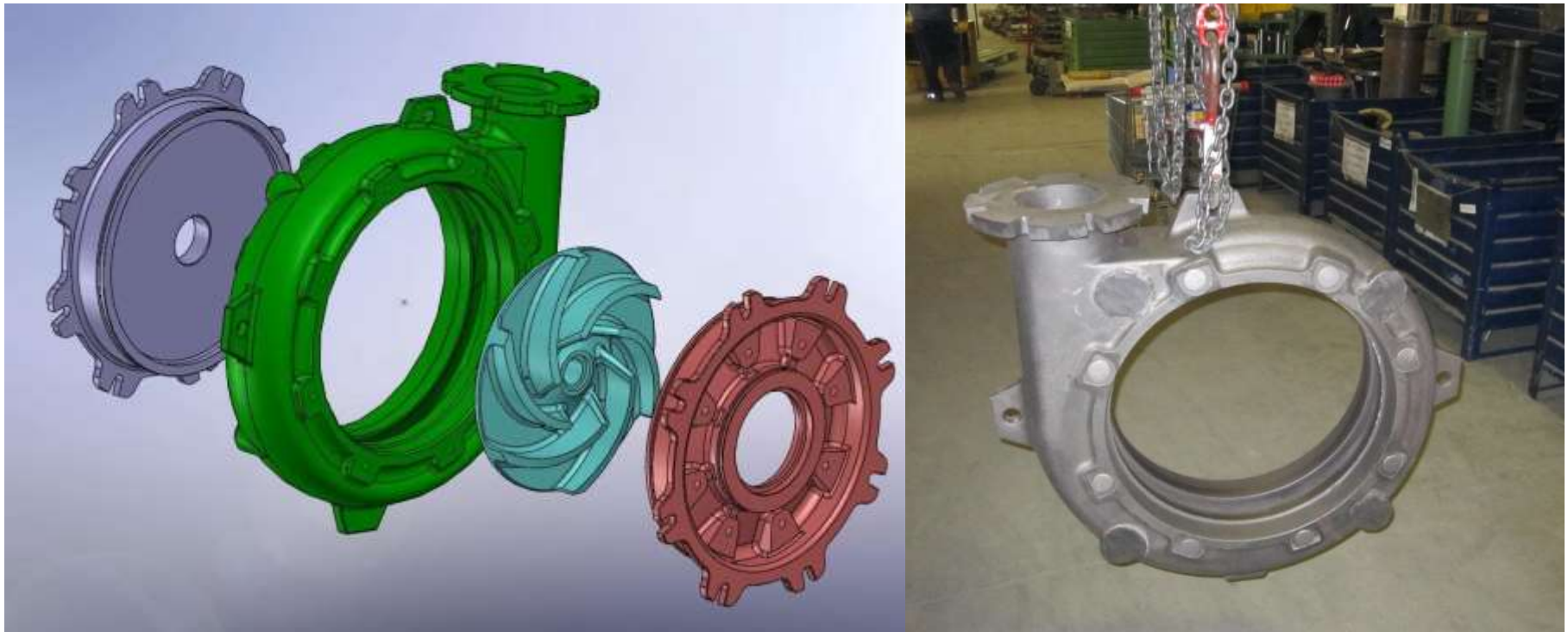

PEMO PUMPS, NEW IN 2012 (2)

- One all casted pump (AISI, Hastelloy), for specific acid applications (i.e. metal refining in mining), flows up to 100 m³/h (400 GPM)

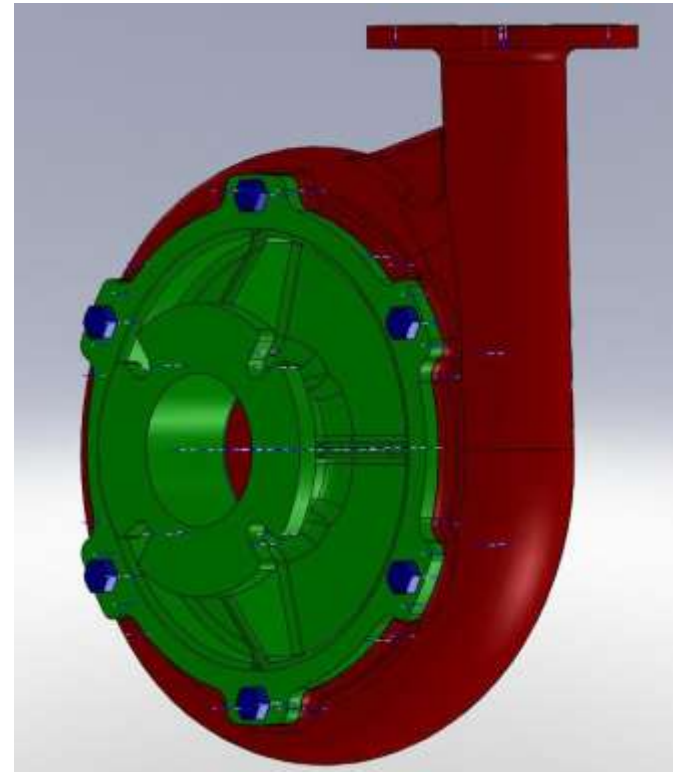
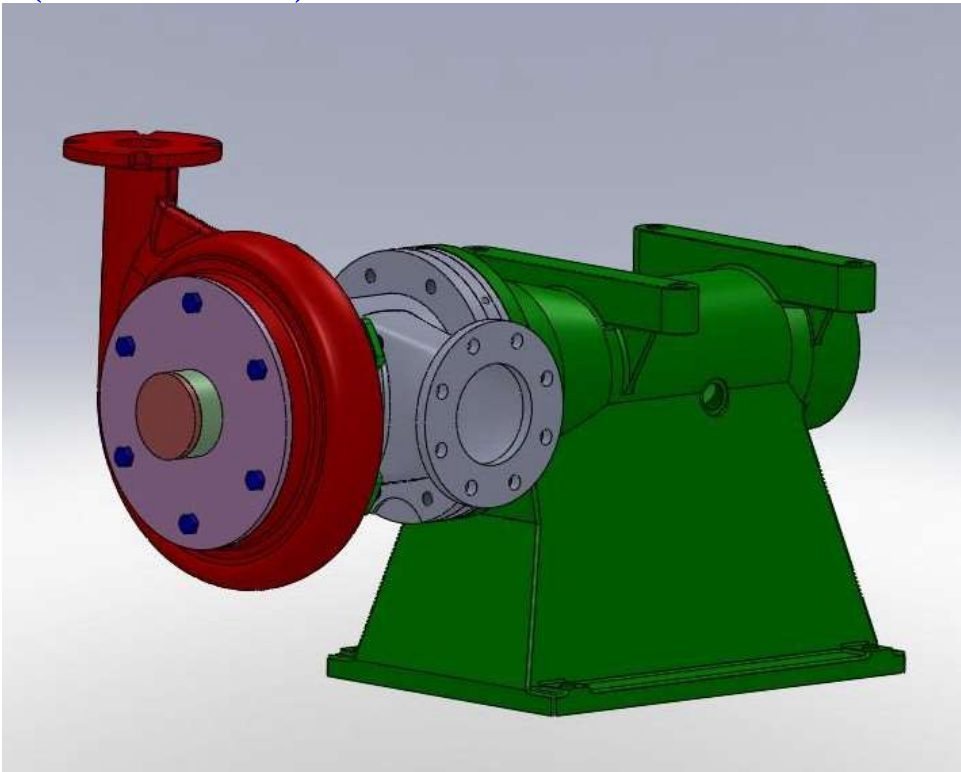

PEMO PUMPS TECHNOLOGY FOR THE TRANSFER OF SLURRIES

- Output Pressure for new versions of Hardalloy triple stage pumps can reach 180 m/H₂O (about 600 feet)
- Installed power ranges from 0.4 to 250 kW (0.5 to 340 Hp)
- The rotational speeds vary from 450 to 2900 rpm at 50 Hz
- Weight of the pumps are between 30 and 3000 kg (60 to 6600 lbs)



MECHANICAL PARTS

- All the mechanical parts (i.e. Shafts bases bearings) are generously over-sized extending longer life of the pump.
- Whenever possible, our aim is to create a compact, heavy-duty, cosmetic pleasant appearing unit.
- **“Mechanical Refresh Program”** Starting from the year 2000, a general updating has being carried out on all pumps. However due to the large number of models and versions involved this process take a few years to complete.

PEMO PUMPS, THE VERSIONS

Pemo Pumps can be built in the following versions:

- **Vertical**
- **Horizontal**
- **Submersed**
- **Multi-Stage**

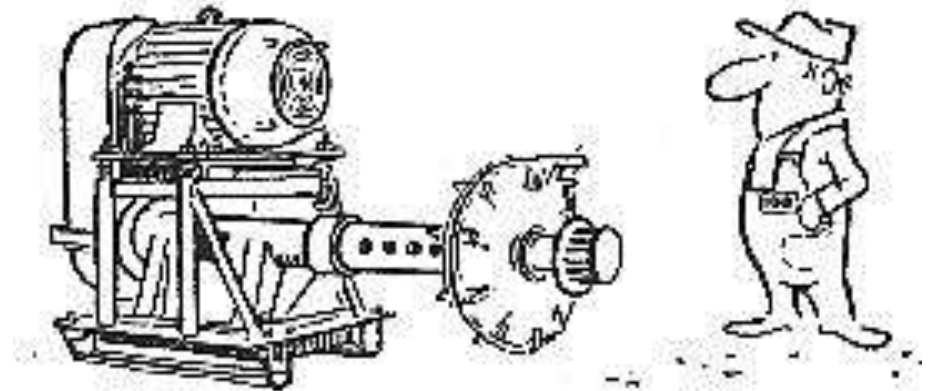

By mixing all the mechanical versions and the Models have resulted in more than 3000 different PEMO Pumps that can be built.

THE VERTICAL VERSIONS

- **JOLLY Series**
- **MEC Series**
- **AVC/L, AVM/L and AV/L Series**
- **AUS/V, AUS/VA and AUS/VE Series**

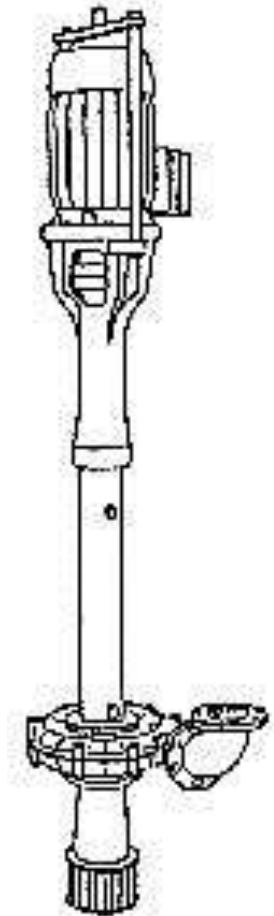

MECHANICAL FEATURES COMMON TO ALL VERTICAL PEMO PUMPS

- When present the *sealing system*, is of the guiding bush / sleeve type (just above the casings) this also works as sort of an additional lower bearing. It is made of an anti-abrasive material (rubber, urethane, Hardalloy PEMO)
- Lubrication of the bush/sleeve systems is made by the pumped liquid itself that lets in a small amount of approximately 5% maximum.
- All the bearing are grease lubricated.

JOLLY SERIES

- The shaft is always supported above the baseplate by 2 bearings inside the base;
- The pump-motor coupling is by means of elastic joint or with V-belts. The maximum length of the pump under the base can reach 4-5 meters (13ft to 16ft)

Due to the presence of bush and sleeve as sealing system, the pumps of the JOLLY series cannot run dry.



PEMO PUMPS TECHNOLOGY FOR THE TRANSFER OF SLURRIES

MEC SERIES

These pumps are similar to the Jolly Series, however they only have direct transmission by means of elastic joint. There is always a metallic structure around the motor at the top of which is placed a lifting eyebolt. Lengths under the bases are standard and do not exceed 2 meter (7ft).

These pumps, as per the JOLLY Series, usually cannot run dry.



AVC/L, AVM/L and AV/L SERIES

- These are very simple pumps with direct coupling whose distinctive feature is to have the shaft of the motor in an extended and oversized version. The maximum length under the baseplate is of 1.5 meters (5 ft).
- The lower seal is of the bush-sleeve type that is the reason why they cannot run dry.
- The maximum power is of 30 kW. These pumps are recommended for slightly abrasive slurries.



AUS/V, AUS/VA and AUS/VE SERIES

- An important factor of these pumps is that they can run dry since there is no mechanical seal.
- Mechanically speaking these pumps are the same as the JOLLY series but the maximum length of the pump under the base seldom exceeds 1,5 meters (5 ft).
- Usually the fluid inlet is above the casings but in some versions it is also at the bottom (double sided impellers).

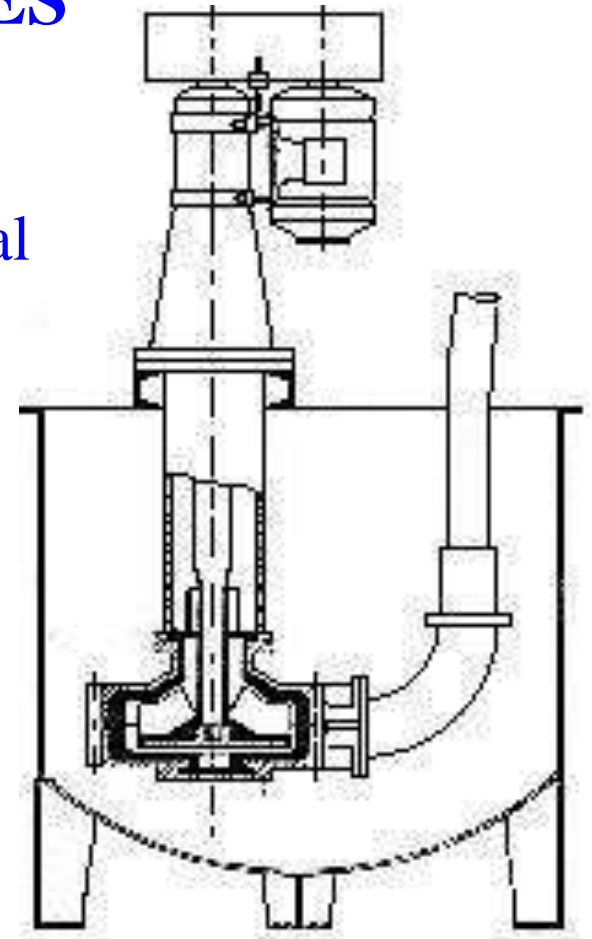

AUS, AUS/VA and AUS/VE SERIES

More in detail, the **AUS/V Series** consists of the pump only.

The **AUS/VA Series** consists of the pump and of one tank, with the pump inserted in the tank and the casing-impeller unit at its bottom.

In mining, these are pumps for froth collection



PEMO PUMPS TECHNOLOGY FOR THE TRANSFER OF SLURRIES

AUS, AUS/VA and AUS/VE SERIES

The **AUS/VE Series** consists of pumps with a flanged side inlet, to be applied externally to one tank. These pumps have a very easy maintenance



THE HORIZONTAL VERSIONS

PEMO Pumps can be built in the following versions:

- **AO** \
- **AO/TD** => **V-Belts**
- **AO/AB** /

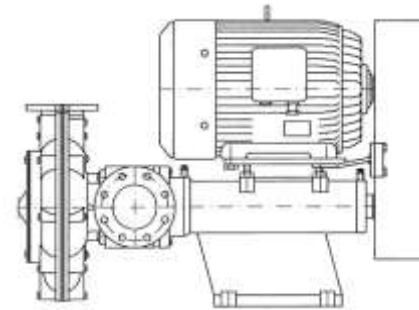

- **AO-AD** \
- **AO/TD-AD** => **Direct Transmission**
- **AO/AB-AD** /

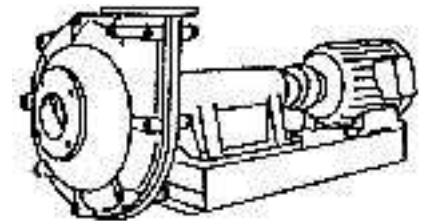

MECHANICAL FEATURES COMMON TO THE HORIZONTAL PEMO PUMPS

- All the PEMO horizontal pumps have the sealing system that consists of mechanical seals, with faces that are made of Tungsten Carbide (widia) or of Silica Carbide
- Lubrication of the mechanical seals, when there is a pair per pump, can be made with flushing water at a determined pressure, depending on the version,, or with water/glicole by means of a closed circuit with natural or forced circulation.
- Lubrication of the bearings is made with grease or with oil.

AO and AO-AD SERIES

- These are “standard” horizontal pumps with frontal inlet.
- Since there is only one mechanical seal these models are used to pump only water-like fluids with almost no abrasive particles.
- The maximum available pressure does not exceed 2 bar (29 psi).
- There is limited production on these per year



PEMO PUMPS TECHNOLOGY FOR THE TRANSFER OF SLURRIES

AO/TD and AO/TD-AD SERIES

- These are horizontal pumps with frontal inlet and double mechanical seals, flushing is at a pressure that is higher than the slurry outlet pressure.
- They can be used to pump abrasive and/or acid liquids.
- Maximum outlet pressure should not exceed 3-4 bar. (45 - 60 psi)



AO/AB and AO/AB-AD SERIES

- One of our most popular and distinctive products, thanks to the side inlet, the maximum pressure that the mechanical seals stand is the fluid inlet pressure, greatly increasing life expectancy.
- When pumping acid liquids, the shaft and the mechanical seal housing can be made of special alloys.



SUBMERSIBLE VERSIONS:

- Submersed PEMO Pumps are manufactured with power ranging from 0.75 to 75 kW, (1 HP to 100 HP) and velocities from 735 to 2900 rpm.
- Usually maximum flow does not exceed 6000 l/min (360 m³/h – 1600 GPM) and pressures seldom reach 6-7 bar (85–100 psi)
- These pumps in some cases have the longest delivery time due to motor availability



MECHANICAL FEATURES COMMON TO ALL THE SUBMERSED PEMO PUMPS

- All the sealing system is made with 2 mechanical seals, that are in a closed chamber and are oil lubricated
- Bearings are of the long-life type, grease lubricated
- All pumps are provided with thermal probes (for the control of the temperature of the motor) and one oil level probe (for the detection of leakages of slurry inside the oil chamber)
- All the pumps are sold with an electric device for the analysis of the signals from the probes

THE MULTI STAGE VERSIONS

Multi Stage PEMO Pumps are mostly manufactured in the AO/AB/DC versions, i.e. in a double stage horizontal version with side-suction.

New all-Hardalloy versions are built in order to reach 24 bar (350 psi) with ceramic slip or metal concentrates



THE DOUBLE STAGE VERSIONS

When to use them?

Double Stage PEMO Pumps can reach pressures of 12-24 bars/H₂O (175-350 psi), they become the perfect solution for the feeding of Filter presses, or they transfer Slurries when the geodetical distances or the pressure loss due to the piping are very high. Presently ten models of PEMO DC pumps are built with power from 30 to 250 kW (40 –340 hp) and flows from 30 to 600 m³/h (130-2650 GPM)



PEMO PUMPS TECHNOLOGY FOR THE TRANSFER OF SLURRIES

THE TRIPLE STAGE VERSIONS

- The Triple Stage Pumps, are used with pressures up to 24 bars, 24 h/day, in Ceramic Industry, to feed Spray Dryers



MECHANICAL FEATURES COMMON TO ALL MULTI STAGE (DC & TC) PEMO PUMPS

- All the mechanical seals are made of Silica or Tungsten Carbide (widia)
- Lubrication of the 2 mechanical seals can be made with flushing water at one pressure that is at least 1 bar higher than the slurry inlet pressure (NOT the outlet!!!) to the pump, or with water/glicole by means of a closed circuit
- Lubrication of the bearings is with oil only in the horizontal versions
- Motors are usually controlled by inverters

OTHER PRODUCTS by PERISSINOTTO SpA

Valves (pinch type):

Made with separable linings that can be made of different rubber compositions they are used when pumping highly abrasive materials.

The PEMO valves can be manual or pneumatic, with inner diameters up to 250 mm (10 inches)



OTHER PRODUCTS by PERISSINOTTO SpA

Rubber Pipings and Aluminium Flanges

Available in different dimensions, they always have different rubber and textile layers with metal coils reinforcement. Aluminium flanges, split in 2 halves and to be mounted at the ends of the rubber pipings, are also available

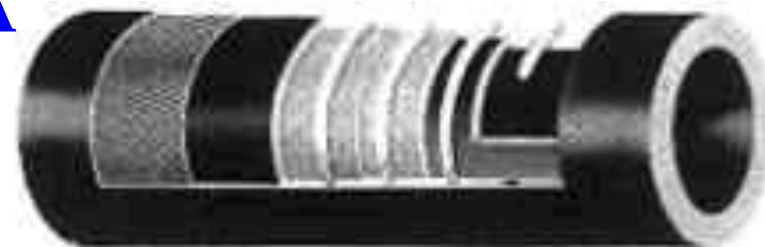

OTHER PRODUCTS by PERISSINOTTO SpA

Cyclons:

Coated internally with rubber, ceramic or polyurethane, PEMO cyclons consist of modules that can be assembled in order to obtain different sizes.

- Standard flows for our cyclons vary between 30 and 600 m³/h (130 – 2650 GPM) with a maximum pressure inlet of 3 bar (43,5 psi)

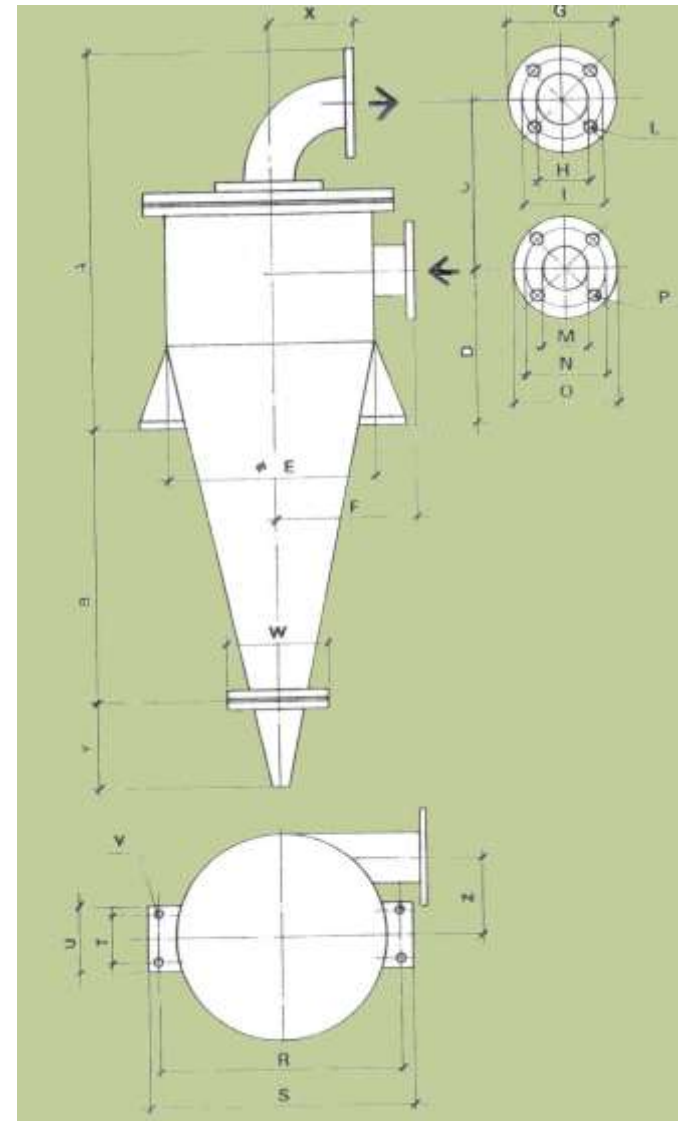



**THANK YOU FOR
YOUR ATTENTION!!**